



Bid Number: GEM/2022/B/2104144
Dated: 02-05-2022

Bid Document

Bid Details	
Bid End Date/Time	01-06-2022 15:00:00
Bid Opening Date/Time	01-06-2022 15:30:00
Bid Life Cycle (From Publish Date)	90 (Days)
Bid Offer Validity (From End Date)	60 (Days)
Ministry/State Name	Ministry Of Finance
Department Name	Department Of Economic Affairs
Organisation Name	Security Printing And Minting Corporation Of India Limited (spmci)
Office Name	Janpath
Total Quantity	24
Item Category	Hydro Jet Nozzle with RUBBY ORIFICE (Q3)
MSE Exemption for Years Of Experience and Turnover	Yes
Startup Exemption for Years Of Experience and Turnover	Yes
Document required from seller	Certificate (Requested in ATC),OEM Authorization Certificate,Additional Doc 1 (Requested in ATC) *In case any bidder is seeking exemption from Experience / Turnover Criteria, the supporting documents to prove his eligibility for exemption must be uploaded for evaluation by the buyer
Bid to RA enabled	No
Time allowed for Technical Clarifications during technical evaluation	2 Days
Evaluation Method	Total value wise evaluation

EMD Detail

Required	No
----------	----

ePBG Detail

Required	No
----------	----

Splitting

Bid splitting not applied.

MII Purchase Preference

MII Purchase Preference	Yes
-------------------------	-----

MSE Purchase Preference

MSE Purchase Preference	Yes
-------------------------	-----

1. If the bidder is a Micro or Small Enterprise as per latest definitions under MSME rules, the bidder shall be exempted from the requirement of "Bidder Turnover" criteria and "Experience Criteria". If the bidder is OEM of the offered products, it would also be exempted from the "OEM Average Turnover" criteria. In case any bidder is seeking exemption from Turnover / Experience Criteria, the supporting documents to prove his eligibility for exemption must be uploaded for evaluation by the buyer.
2. If the bidder is a Startup, the bidder shall be exempted from the requirement of "Bidder Turnover" criteria and "Experience Criteria". If the bidder is OEM of the offered products, it would also be exempted from the "OEM Average Turnover" criteria. In case any bidder is seeking exemption from Turnover / Experience Criteria, the supporting documents to prove his eligibility for exemption must be uploaded for evaluation by the buyer.
3. Preference to Make In India products (For bids < 200 Crore):Preference shall be given to Class 1 local supplier as defined in public procurement (Preference to Make in India), Order 2017 as amended from time to time and its subsequent Orders/Notifications issued by concerned Nodal Ministry for specific Goods/Products. The minimum local content to qualify as a Class 1 local supplier is denoted in the bid document. If the bidder wants to avail the Purchase preference, the bidder must upload a certificate from the OEM regarding the percentage of the local content and the details of locations at which the local value addition is made along with their bid, failing which no purchase preference shall be granted. In case the bid value is more than Rs 10 Crore, the declaration relating to percentage of local content shall be certified by the statutory auditor or cost auditor, if the OEM is a company and by a practicing cost accountant or a chartered accountant for OEMs other than companies as per the Public Procurement (preference to Make-in -India) order 2017 dated 04.06.2020. Only Class-I and Class-II Local suppliers as per MII order dated 4.6.2020 will be eligible to bid. Non - Local suppliers as per MII order dated 04.06.2020 are not eligible to participate. However, eligible micro and small enterprises will be allowed to participate .In case Buyer has selected Purchase preference to Micro and Small Enterprises clause in the bid, the same will get precedence over this clause.
4. Purchase preference to Micro and Small Enterprises (MSEs): Purchase preference will be given to MSEs as defined in Public Procurement Policy for Micro and Small Enterprises (MSEs) Order, 2012 dated 23.03.2012 issued by Ministry of Micro, Small and Medium Enterprises and its subsequent Orders/Notifications issued by concerned Ministry. If the bidder wants to avail the Purchase preference, the bidder must be the manufacturer of the offered product in case of bid for supply of goods. Traders are excluded from the purview of Public Procurement Policy for Micro and Small Enterprises. In respect of bid for Services, the bidder must be the Service provider of the offered Service. Relevant documentary evidence in this regard shall be uploaded along with the bid in respect of the offered product or service. If L-1 is not an MSE and MSE Seller (s) has/have quoted price within L-1+ 15% (Selected by Buyer)of margin of purchase preference /price band defined in relevant policy, such Seller shall be given opportunity to match L-1 price and contract will be awarded for 25%(selected by Buyer) percentage of total QUANTITY.
5. Estimated Bid Value indicated above is being declared solely for the purpose of guidance on EMD amount and for determining the Eligibility Criteria related to Turn Over, Past Performance and Project / Past Experience etc. This has no relevance or bearing on the price to be quoted by the bidders and is also not going to have any impact on bid participation. Also this is not going to be used as a criteria in determining reasonableness of quoted prices which would be determined by the buyer based on its own assessment of reasonableness and based on competitive prices received in Bid / RA process.

Hydro Jet Nozzle With RUBBY ORIFICE (24 pieces)

(Minimum 50% and 20% Local Content required for qualifying as Class 1 and Class 2 Local Supplier respectively)

Brand Type	Unbranded
------------	-----------

Technical Specifications

Buyer Specification Document	Download
------------------------------	--------------------------

Additional Specification Documents

DrawingDocument1	View
------------------	----------------------

Consignees/Reporting Officer and Quantity

S.No.	Consignee/Reporting Officer	Address	Delivery Schedule (In number of days from contract start days)		
			Quantity	Delivery to start after	Delivery to be completed by
1	Neeraj Kumar	461005,Security Paper Mill ,Hoshangabad , Madhya Pradesh	24	1	90

Buyer Added Bid Specific Terms and Conditions

1. Certificates

Bidder's offer is liable to be rejected if they don't upload any of the certificates / documents sought in the Bid document, ATC and Corrigendum if any.

2. Generic

OPTION CLAUSE: The Purchaser reserves the right to increase or decrease the quantity to be ordered up to 25 percent of bid quantity at the time of placement of contract. The purchaser also reserves the right to increase the ordered quantity by up to 25% of the contracted quantity during the currency of the contract at the contracted rates. Bidders are bound to accept the orders accordingly.

3. Generic

Upload Manufacturer authorization: Wherever Authorised Distributors are submitting the bid, Manufacturers Authorisation Form (MAF)/Certificate with OEM details such as name, designation, address, e-mail Id and Phone No. required to be furnished along with the bid.

4. Buyer Added Bid Specific ATC

Buyer Added text based ATC clauses

i. Required Terms of Delivery: F.O.R. Security Paper Mill Narmadapuram (Duly Unloaded) Transport the contracted material/supplies only through Registered Common Carriers.

ii. Payment Terms: 100% on receipt and acceptance (suitability) of goods by the SPM, Narmadapuram and on production of all required documents by the supplier.

iii. Bidder Should Quote Prices Inclusive of GST And All Cost Components Such As Packing & Forwarding Details, Freight & Insurance Charges upto Destination etc. on FOR Security Paper Mill, Narmadapuram (Madhya Pradesh), India basis only.

iv. **Liquidated Damages (LD) Clause:** If the contractor fails to deliver the goods and/or services or any installment thereof within the Delivery Period, SPM Hoshangabad shall, without prejudice to other rights and remedies available to SPM, Hoshangabad under the contract, deduct from the contract price, as Liquidated damages, a sum equivalent to the rate of 0.5 Percent of the delivered price of the delayed goods and/or services along with applicable GST of 18% on the LD amount for each week of delay or part thereof until actual delivery or performance, subject to a maximum deduction of the 10% (plus GST on the LD amount) of the delayed goods or services.

v. The terms and conditions, guidelines of SPMCIL Procurement Manual Version 2.0 will be applicable to this bid at any stage to avoid any conflict at later stage. Kindly refer General Instructions to Tenderer (GIT) and General Conditions of Contract (GCC) of SPMCIL Procurement Manual Version 2.0 for additional terms and conditions as per the links given below:

GIT: <https://spmCIL.com/uploaddocument/GIT/new.pdf>

GCC: <https://spmCIL.com/uploaddocument/GCC/new.pdf>

vi. SPM (as Buyer) is liable to deduct TDS u/s 194Q @ applicable rate on goods purchases (if applicable). In case of deduction of TDS under section 194Q; the Supplier (Vendor) need not to charge TCS u/s 206C (1H) on invoicing on or after 01.07.2021.

vii. Vendor has to submit declaration (*refer Buyer added Specific ATC*) in specified format for the compliance of Section 206AB of Income Tax Act, 1961. In case of non-submission of declaration; TDS will be deducted at higher rates (as applicable) as per section 206AB.

viii. **GST Return:** Supplier should file the GST returns for outward supplies in time. In case of any Input Credit Loss to SPM by way of their failure to files GST Returns in time, SPM reserves the right to withhold the payment of further supplies till production of evidence of filling of Returns.

ix. Manufacturer Authorization Certificate:

(a) If the bidder firm is manufacturer then firm has to submit the valid registration certificate.

(b) If the bidder firm is not the manufacturer then firm has to submit the valid manufacturer's authorization certificate/valid dealership certificate of the item supplied as per the standard form duly filled by OEM as per Annexure-XIV (*refer Buyer added Specific ATC*) of this tender document.

x. Bidder shall submit duly seal & signed copy of **Section VII: Technical Specifications.**

xi. **Delivery Schedule:** Delivery Schedule shall be as per below:

a. 24 no's in between 1 to 90 days from the date of issue of contract in GeM.

5. Buyer Added Bid Specific ATC

Buyer uploaded ATC document [Click here to view the file.](#)

6. Warranty

Warranty period of the supplied products shall be 1 years from the date of final acceptance of goods or after completion of installation, commissioning & testing of goods (if included in the scope of supply), at consignee location. OEM Warranty certificates must be submitted by Successful Bidder at the time of

delivery of Goods. The seller should guarantee the rectification of goods in case of any break down during the guarantee period. Seller should have well established Installation, Commissioning, Training, Troubleshooting and Maintenance Service group in INDIA for attending the after sales service. Details of Service Centres near consignee destinations are to be uploaded along with the bid.

Disclaimer

The additional terms and conditions have been incorporated by the Buyer after approval of the Competent Authority in Buyer Organization. Buyer organization is solely responsible for the impact of these clauses on the bidding process, its outcome and consequences thereof including any eccentricity / restriction arising in the bidding process due to these ATCs and due to modification of technical specification and / or terms and conditions governing the bid. Any clause incorporated by the Buyer such as demanding Tender Sample, incorporating any clause against the MSME policy and Preference to make in India Policy, mandating any Brand names or Foreign Certification, changing the default time period for Acceptance of material or payment timeline governed by OM of Department of Expenditure shall be null and void and would not be considered part of bid. Further any reference of conditions published on any external site or reference to external documents / clauses shall also be null and void. If any seller has any objection / grievance against these additional clauses or otherwise on any aspect of this bid, they can raise their representation against the same by using the Representation window provided in the bid details field in Seller dashboard after logging in as a seller within 4 days of bid publication on GeM. Buyer is duty bound to reply to all such representations and would not be allowed to open bids if he fails to reply to such representations.

This Bid is also governed by the General Terms and Conditions

In terms of GeM GTC clause 26 regarding Restrictions on procurement from a bidder of a country which shares a land border with India, any bidder from a country which shares a land border with India will be eligible to bid in this tender only if the bidder is registered with the Competent Authority. While participating in bid, Bidder has to undertake compliance of this and any false declaration and non-compliance of this would be a ground for immediate termination of the contract and further legal action in accordance with the laws.

---Thank You---



Section VII: Technical Specifications

MATERIAL DESCRIPTION: HYDRO JET NOZZLE WITH RUBY ORIFICE

Hydro single jet nozzle
Diameter 0.6 mm to 0.7 mm
Operating pressure max 40 bar
Water consumption in liter/min 1.5 to 2 LPM
Nozzle Strainer 200 with μm

Orifice material
Synthetic ruby single orifice

Maximum pressure 120 bar
Maximum Temperature 120 degree Celsius

Annexure-I (Drawing)
Annexure-II (Drawing)
Annexure-III(Drawing)

ANNEXURE-I

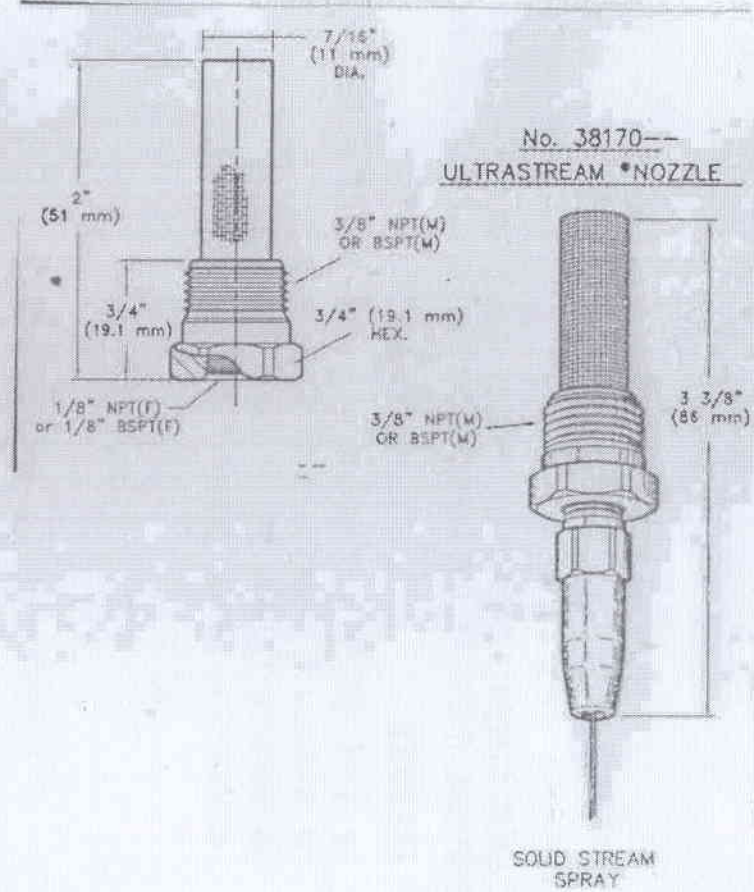

THE SOLID STREAM ULTRASTREAM[®] NOZZLE IS DESIGNED TO TRIM THE PAPER WEB BEFORE IT ENTERS THE PRESS SECTION OF THE PAPER MACHINE.

FEATURES:

- TYPE 303 STAINLESS BODY WITH RUBY ORIFICE INSERT.
- MAXIMUM PRESSURE – 2000 PSI (138 bar).
- MAXIMUM TEMPERATURE – 250° F (121° C).
- WEIGHT – 1.6 OZ. (46 gr.)

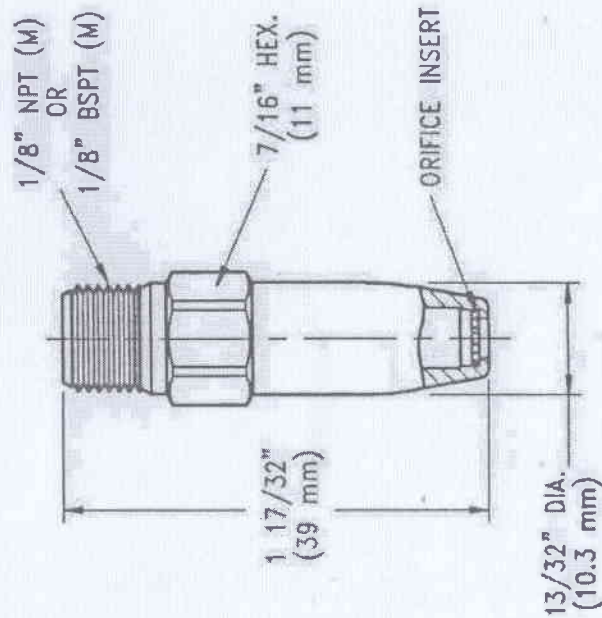

ASSEMBLY

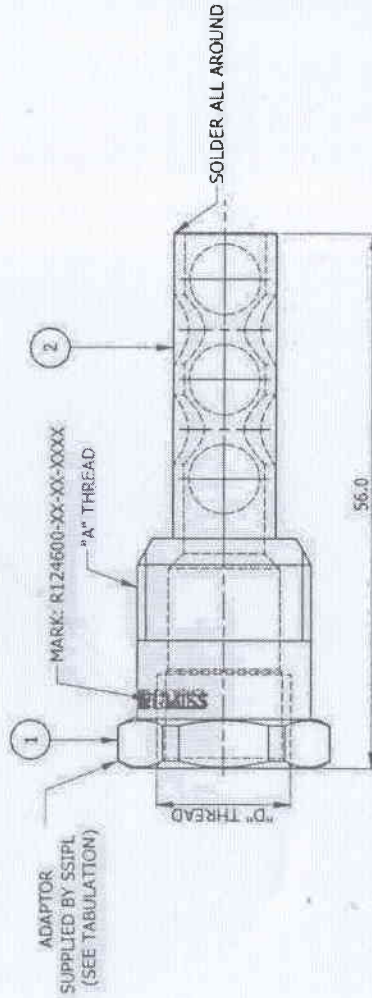
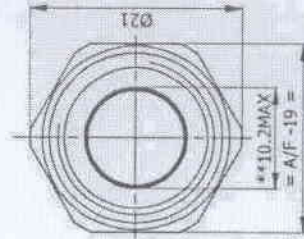
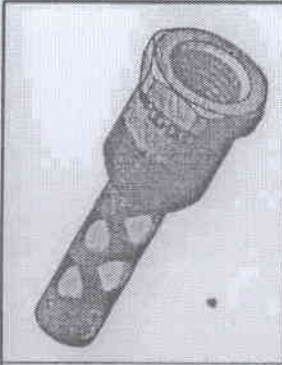

ORDER SPECIFICATION :



* NOTE : WHEN JOINING MESH TO ADAPTOR MAKE SURE ACTUAL SIZE MATCHES MARKING ON ADAPTOR (EX: 40 = 40 MESH)

** MESH OD SHOULD NOT BE MORE THAN $\varnothing 11.4 \pm 0.1$

ANNEXURE-I

Declaration for Section 206AB of TDS under income tax Act, 1961

(to be submitted on Letter Head)

Vendor Code: _____

M/s _____

PAN _____

• GSTIN _____

I/We _____ <Legal Name and complete address > _____, PAN: _____ <PAN no.> _____, TAN: _____ <TAN no.> _____, referring to the provisions of 206AB of the IT Act, 1961, hereby declare the following:-

Financial Year	Aggregate TDS & TCS credit in our name was Rs. 50,000 or more ("Yes / No")	Income Tax Return ("ITR") Filed ("Yes/No")	E-filing Acknowledgment Number (15 digit - numeric) (Attach copy of acknowledgments)	Date of Filing of Return of Income u/s 139(1) (DD/MM/YYYY)	Linked PAN with Aadhaar number or will link it before 30 Jun 2021 (or any further date as may be notified by CBDT ("Yes / No"))
2018-19					
2019-20					

We do hereby declare that to the best of my /our knowledge and belief what is stated above is correct, complete and is truly stated. In case there is a tax liability, interest or penal consequences which are levied on SPM on account of the false representation/ declaration, I/we undertake to fully indemnify SPM for the same.

FOR _____

Authorized Signatory

Date:

Note: In case the vendor failed to comply with the above provisions, TDS shall be deducted at the higher of the following rates, namely: -

- (i) at twice the rate specified in the relevant provision of the Act; or*
- (ii) at twice the rate or rates in force; or*
- (iii) at the rate of five per cent (5%).*

(To be submitted on the Letter Head)
• DECLARATION

We do hereby declare that,

1. We have not been blacklisted/debarred by BNPMIPL/BRBNMPL/SPMCIL or any Govt. Departments for participation in tenders. The information provided above is correct and true to the best of my knowledge and belief.
2. We do hereby declare that we have read and understood all terms and conditions of tender document including GIT, SIT, GCC, SCC, Technical Specification, Quality Control Criteria and confirm to abide to those conditions without any counter conditions.
3. We are accepting all the terms and conditions of the tender document without any deviation and withdraw all deviations if any.

Signature.....

Name.....

Designation.....

Date.....

Stamp of the Organization.....

(To be submitted on the Letter Head)

**DECLARATION
(Refer GIT Clause No.3.5)**

"I have read the clause regarding restrictions on procurement from a bidder of a country which shares a land border with India. I certify that M/s..... (Firm's name) is not from such a country or, if from such a country, has been registered with the Competent Authority. I hereby certify that M/s..... (Firm's name) fulfils at requirements in this regard and is eligible to be considered." (Where applicable, evidence of valid registration by the competent Authority shall be attached)"

I, the undersigned, declare that the item originates in..... (Name of the country).

Signature.....

Name.....

Designation.....

Date.....

Stamp of the Organization.....

(To be submitted on the letter head of the manufacturing firm)

SECTION XIV: MANUFACTURER'S AUTHORIZATION FORM

To,

Security Paper Mill, Hoshangabad
A Unit of Security Printing & Minting
Corporation of India Limited
(Wholly Owned by Govt. of India)
Hoshangabad

Ref: Your Tender document No, dated

We,.....who are proven and reputable manufacturers of
..... (Name and description of the goods offered in the tender) having factories
at hereby authorize Messrs (name and
address of the agent) to submit a tender, process the same further and enter into a contract with
you against your requirement as contained in the above referred tender enquiry documents for
the above goods manufactured by us.

We further confirm that no supplier or firm or individual other than Messrs.....
..... (name and address of the above agent) is authorized to submit a tender,
process the same further and enter into a contract with you against your requirement as
contained in the above referred tender enquiry documents for the above goods manufactured by
us.

We also hereby extend our full warranty, as applicable as per clause 16 of the General Conditions
of Contract read with modification, if any, in the Special Conditions of Contract for the goods and
services offered for supply by the above firm against this tender document.

Yours faithfully,

.....
.....

[Signature with date, name, and designation]
for and on behalf of Messrs.....?
Name & address of the manufacturers

*Note: This letter of authorization should be on the letter head of the manufacturing firm and should
be signed by a person competent and having the power of attorney to legally bind the manufacturer.*

CHECKLIST OF DOCUMENTS FOR TECHNICAL BID

S. No.	Documents Required	Submitted (✓)
1.	Earnest Money Deposit (EMD) (Exempted for MSME Firm)	NA
2.	Certificate of Local Content as per Public Procurement (Preference to Make in India), Order 2017	()
3.	Duly Seal & Signed Section VII: Technical Specifications	()
4.	Duly Seal & Signed Drawings	()
5.	Buyer added Specific ATC Declarations (Annexure-I, II & III)	()
6.	Manufacturer/OEM Authorization Certificate	()
7.	Acceptance of Delivery Schedule as per Buyer Added Bid Specific Terms and Conditions, Para-4 Buyer Added Bid Specific ATC point no. xi Delivery Schedule	()