

Published bid -



Bid Number: GEM/2022/B/1912043
Dated: 04-02-2022

Bid Document

Bid Details	
Bid End Date/Time	03-03-2022 17:00:00
Bid Opening Date/Time	03-03-2022 17:30:00
Bid Life Cycle (From Publish Date)	90 (Days)
Bid Offer Validity (From End Date)	60 (Days)
Ministry/State Name	Ministry Of Finance
Department Name	Department Of Economic Affairs
Organisation Name	Security Printing And Minting Corporation Of India Limited (spmcl)
Office Name	Janpath
Total Quantity	23
Item Category	Pneumatic operated Knife Gate valve DN 100 (Q3) , Pneumatic operated Knife Gate valve DN 200 (Q3) , Pneumatic operated Knife Gate valve DN 250 (Q3) , Pneumatic operated Knife Gate valve DN 300 (Q3) , Pneumatic operated Knife Gate valve DN 350 (Q3) , Pneumatic operated Knife Gate valve through Conduit DN 150 (Q3) , Pneumatic operated Knife Gate valve DN 125 (Q3)
MSE Exemption for Years Of Experience and Turnover	Yes
Startup Exemption for Years Of Experience and Turnover	Yes
Document required from seller	Certificate (Requested in ATC),OEM Authorization Certificate *In case any bidder is seeking exemption from Experience / Turnover Criteria, the supporting documents to prove his eligibility for exemption must be uploaded for evaluation by the buyer
Bid to RA enabled	No
Primary product category	Pneumatic operated Knife Gate valve through Conduit DN 150
Time allowed for Technical Clarifications during technical evaluation	2 Days
Evaluation Method	Total value wise evaluation

EMD Detail

Advisory Bank	Indusind bank
EMD Percentage(%)	2.00
EMD Amount	86489

ePBG Detail

Advisory Bank	Indusind bank
ePBG Percentage(%)	3.00
Duration of ePBG required (Months).	15

(a). EMD EXEMPTION: The bidder seeking EMD exemption, must submit the valid supporting document for the relevant category as per GeM GTC with the bid. Under MSE category, only manufacturers for goods and Service Providers for Services are eligible for exemption from EMD. Traders are excluded from the purview of this Policy.

(b). EMD & Performance security should be in favour of Beneficiary, wherever it is applicable.

Beneficiary:

HOSHANGABAD
Security Paper Mill, Hoshangabad.
(Security Paper Mill)

Splitting

Bid splitting not applied.

MII Purchase Preference

MII Purchase Preference	Yes
-------------------------	-----

MSE Purchase Preference

MSE Purchase Preference	Yes
-------------------------	-----

1. If the bidder is a Micro or Small Enterprise as per latest definitions under MSME rules, the bidder shall be exempted from the requirement of "Bidder Turnover" criteria and "Experience Criteria". If the bidder is OEM of the offered products, it would also be exempted from the "OEM Average Turnover" criteria. In case any bidder is seeking exemption from Turnover / Experience Criteria, the supporting documents to prove his eligibility for exemption must be uploaded for evaluation by the buyer.
2. If the bidder is a Startup, the bidder shall be exempted from the requirement of "Bidder Turnover" criteria and "Experience Criteria". If the bidder is OEM of the offered products, it would also be exempted from the "OEM Average Turnover" criteria. In case any bidder is seeking exemption from Turnover / Experience Criteria, the supporting documents to prove his eligibility for exemption must be uploaded for evaluation by the buyer.
3. Preference to Make In India products (For bids < 200 Crore):Preference shall be given to Class 1 local supplier as defined in public procurement (Preference to Make in India), Order 2017 as amended from time to time and its subsequent Orders/Notifications issued by concerned Nodal Ministry for specific Goods/Products. The minimum local content to qualify as a Class 1 local supplier is denoted in the bid document. If the bidder wants to avail the Purchase preference, the bidder must upload a certificate from the OEM regarding the percentage of the local content and the details of locations at which the local value addition is made along with their bid, failing which no purchase preference shall be granted. In case the bid value is more than Rs 10 Crore, the declaration relating to percentage of local content shall be certified by the statutory auditor or cost auditor, if the OEM is a company and by a practicing cost accountant or a chartered accountant for OEMs other than companies as per the Public Procurement (preference to Make-in -India) order 2017 dated 04.06.2020. Only Class-I and Class-II Local suppliers as per MII order dated 4.6.2020 will be eligible to bid. Non - Local suppliers as per MII order dated 04.06.2020 are not eligible to participate. However, eligible micro and small enterprises will be allowed to participate .In case Buyer has selected Purchase preference to Micro and Small Enterprises clause in the bid, the same will get

...evidence over this clause.
 Purchase preference to Micro and Small Enterprises (MSEs): Purchase preference will be given to MSEs as defined in Public Procurement Policy for Micro and Small Enterprises (MSEs) Order, 2012 dated 23.03.2012 issued by Ministry of Micro, Small and Medium Enterprises and its subsequent Orders/Notifications issued by concerned Ministry. If the bidder wants to avail the Purchase preference, the bidder must be the manufacturer of the offered product in case of bid for supply of goods. Traders are excluded from the purview of Public Procurement Policy for Micro and Small Enterprises. In respect of bid for Services, the bidder must be the Service provider of the offered Service. Relevant documentary evidence in this regard shall be uploaded along with the bid in respect of the offered product or service. If L-1 is not an MSE and MSE Seller (s) has/have quoted price within L-1+ 15% (Selected by Buyer) of margin of purchase preference /price band defined in relevant policy, such Seller shall be given opportunity to match L-1 price and contract will be awarded for 25%(selected by Buyer) percentage of total QUANTITY.

5. Estimated Bid Value indicated above is being declared solely for the purpose of guidance on EMD amount and for determining the Eligibility Criteria related to Turn Over, Past Performance and Project / Past Experience etc. This has no relevance or bearing on the price to be quoted by the bidders and is also not going to have any impact on bid participation. Also this is not going to be used as a criteria in determining reasonableness of quoted prices which would be determined by the buyer based on its own assessment of reasonableness and based on competitive prices received in Bid / RA process.

Pneumatic Operated Knife Gate Valve DN 100 (2 pieces)

(Minimum 50% Local content required for qualifying as Class 1 Local Supplier)

Brand Type	Unbranded
------------	-----------

Technical Specifications

Buyer Specification Document	Download
------------------------------	--------------------------

Additional Specification Documents

DrawingDocument1	View
------------------	----------------------

Consignees/Reporting Officer and Quantity

S.No.	Consignee/Reporting Officer	Address	Quantity	Delivery Days
1	Amit Yadav	461005,Hoshangabad , Madhya Pradesh	2	30

Pneumatic Operated Knife Gate Valve DN 200 (6 pieces)

(Minimum 50% Local content required for qualifying as Class 1 Local Supplier)

Brand Type	Unbranded
------------	-----------

Technical Specifications

Buyer Specification Document	Download
------------------------------	--------------------------

Additional Specification Documents

DrawingDocument1	View
------------------	----------------------

Consignees/Reporting Officer and Quantity

S.No.	Consignee/Reporting Officer	Address	Quantity	Delivery Days
1	Amit Yadav	461005,Hoshangabad , Madhya Pradesh	6	30

Pneumatic Operated Knife Gate Valve DN 250 (2 pieces)

(Minimum 50% Local content required for qualifying as Class 1 Local Supplier)

Brand Type	Unbranded
------------	-----------

Technical Specifications

Buyer Specification Document	Download
------------------------------	--------------------------

Additional Specification Documents

DrawingDocument1	View
------------------	----------------------

Consignees/Reporting Officer and Quantity

S.No.	Consignee/Reporting Officer	Address	Quantity	Delivery Days
1	Amit Yadav	461005,Hoshangabad , Madhya Pradesh	2	30

Pneumatic Operated Knife Gate Valve DN 300 (3 pieces)

(Minimum 50% Local content required for qualifying as Class 1 Local Supplier)

Brand Type	Unbranded
------------	-----------

Technical Specifications

Buyer Specification Document	Download
------------------------------	--------------------------

Additional Specification Documents

DrawingDocument1	View
------------------	----------------------

Consignees/Reporting Officer and Quantity

S.No.	Consignee/Reporting Officer	Address	Quantity	Delivery Days
1	Amit Yadav	461005,Hoshangabad , Madhya Pradesh	3	30

Pneumatic Operated Knife Gate Valve DN 350 (2 pieces)

(Minimum 50% Local content required for qualifying as Class 1 Local Supplier)

Brand Type	Unbranded
------------	-----------

Technical Specifications

Buyer Specification Document	Download
------------------------------	--------------------------

Additional Specification Documents

DrawingDocument1	View
------------------	----------------------

Consignees/Reporting Officer and Quantity

S.No.	Consignee/Reporting Officer	Address	Quantity	Delivery Days
1	Amit Yadav	461005,Hoshangabad , Madhya Pradesh	2	30

Pneumatic Operated Knife Gate Valve Through Conduit DN 150 (6 pieces)

(Minimum 50% Local content required for qualifying as Class 1 Local Supplier)

Brand Type	Unbranded
------------	-----------

Technical Specifications

Buyer Specification Document [Download](#)

Additional Specification Documents

DrawingDocument1 [View](#)

Consignees/Reporting Officer and Quantity

S.No.	Consignee/Reporting Officer	Address	Quantity	Delivery Days
1	Amit Yadav	461005,Hoshangabad , Madhya Pradesh	6	30

Pneumatic Operated Knife Gate Valve DN 125 (2 pieces)

(Minimum 50% Local content required for qualifying as Class 1 Local Supplier)

Brand Type [Unbranded](#)

Technical Specifications

Buyer Specification Document [Download](#)

Additional Specification Documents

DrawingDocument1 [View](#)

Consignees/Reporting Officer and Quantity

S.No.	Consignee/Reporting Officer	Address	Quantity	Delivery Days
1	Amit Yadav	461005,Hoshangabad , Madhya Pradesh	2	30

Buyer added Bid Specific Additional Scope of Work

S.No.	Document Title	Description	Applicable i.r.o. Items
1	Specification View	Dimension of valves and flange should be as per attached.	Pneumatic Operated Knife Gate Valve DN 100(2)
2	Specification View	Dimension of valves and flange should be as per attached.	Pneumatic Operated Knife Gate Valve DN 200(6)
3	Specification View	Dimension of valves and flange should be as per attached.	Pneumatic Operated Knife Gate Valve DN 250(2)
4	Specification View	Dimension of valves and flange should be as per attached.	Pneumatic Operated Knife Gate Valve DN 300(3)
5	Specification View	Dimension of valves and flange should be as per attached.	Pneumatic Operated Knife Gate Valve DN 350(2)
6	Specification View	Dimension of valves and flange should be as per attached.	Pneumatic Operated Knife Gate Valve Through Conduit DN 150(6)
7	Specification View	Dimension of valves and flange should be as per attached.	Pneumatic Operated Knife Gate Valve DN 125(2)

The uploaded document only contains Buyer specific Additional Scope of Work and / or Drawings for the bid items added with due approval of Buyer's competent authority. Buyer has certified that these additional scope and drawings are generalized and would not lead to any restrictive bidding.

Buyer Added Bid Specific Terms and Conditions

1. Forms of EMD and PBG

Bidders can also submit the EMD with Account Payee Demand Draft in favour of SECURITY PAPER MILL payable at HOSHANGABAD.
Bidder has to upload scanned copy / proof of the DD along with bid and has to ensure delivery of hardcopy to the Buyer within 5 days of Bid End date / Bid Opening date.

2. Forms of EMD and PBG

Bidders can also submit the EMD with Fixed Deposit Receipt made out or pledged in the name of SECURITY PAPER MILL, HOSHANGABAD A/C (Name of the Seller). The bank should certify on it that the deposit can be withdrawn only on the demand or with the sanction of the pledgee. For release of EMD, the FDR will be released in favour of bidder by the Buyer after making endorsement on the back of the FDR duly signed and stamped along with covering letter.
Bidder has to upload scanned copy / proof of the FDR along with bid and has to ensure delivery of hardcopy to the Buyer within 5 days of Bid End date / Bid Opening date.

3. Certificates

Bidder's offer is liable to be rejected if they don't upload any of the certificates / documents sought in the Bid document, ATC and Corrigendum if any.

4. Generic

Bidders are advised to check applicable GST on their own before quoting. Buyer will not take any responsibility in this regards. GST reimbursement will be as per actuals or as per applicable rates (whichever is lower), subject to the maximum of quoted GST %.

5. Buyer Added Bid Specific ATC

Buyer Added text based ATC clauses

1. 100% PAYMENT SHALL BE DONE ON RECEIPT AND ACCEPTANCE OF GOODS BY THE PURCHASER AND ON PRODUCTION OF ALL REQUIRED DOCUMENTS BY THE SUPPLIER.
2. F.O.R- SPM, HOSHANGABAD DULY UNLOADED.
3. MAKE OF VALVES:- LOHSE, ORBINOX, VADE OR EQUIVALENT.
4. EXPERIENCE & PAST PERFORMANCE:- THE BIDDER (MANUFACTURER OR PRINCIPAL OF AUTHORISED REPRESENTATIVE HERIN AFTER REFERRED SIMPLY AS THE BIDDER)SHALL BE A MANUFACTURER THAT HAS REGULARLY FOR AT LEAST THE LAST THREE YEARS MANUFACTURED, SUPPLIED, ERECTED, COMMISSIONED KNIFE GATE VALVE WITH THE SAME OR HIGHER SPECIFICATIONS OF KNIFE GATE VALVE DN 150 THROUGH CONDUIT OF AT LEAST ONE NUMBER IN LAST FIVE YEARS ENDING ON 31.03.2021. AT LEAST ONE NUMBER OF THE PRODUCT OFFERED FOR SUPPLY SHOULD BE IN SUCCESSFUL OPERATION FOR AT LEAST ONE YEAR ON THE DATE OF BID OPENING.
5. CAPABILITY EQUIPMENT & MANUFACTURING FACILITIES:- THE BIDDER MUST HAVE AN ANNUAL CAPACITY TO MANUFACTURE AND SUPPLY AT LEAST 13 NUMBERS OF KNIFE GATE VALVES.
6. FINANCIAL STANDING:- THE AVERAGE ANNUAL FINANCIAL TURNOVER OF THE BIDDER DURING THE LAST THREE YEARS, ENDING ON 31.03.2021, SHOULD BE AT LEAST RS. 17,30,000.00 LAKHS AS PER THE ANNUAL REPORT (AUDITED BALANCE SHEET AND PROFIT & LOSS ACCOUNT) UPTO 31.03.2021, DULY AUTHENTICATED BY A CHARTERED ACCOUNTANT/COST ACCOUNTANT IN INDIA OR EQUIVALENT IN RELEVANT COUNTRIES.
 2. THE BIDDER SHOULD NOT HAVE SUFFERED ANY FINANCIAL LOSS FOR MORE THAN ONE YEAR DURING THE LAST THREE YEARS, ENDING ON 31.03.2021.
 - I) THE NETWORTH OF THE BIDDER SHOULD NOT BE NEGATIVE ON 31.03.2021.
 - II) SHOULD NOT HAVE ERODED BY MORE THAN 30% IN THE LAST THREE YEARS, ENDING ON 31.03.2021.
7. KINDLY SUBMIT THE BUYER ADDED DOCUMENT ASKED IN THE BID.

6. Warranty

Warranty period of the supplied products shall be 1 years from the date of final acceptance of goods or after completion of installation, commissioning & testing of goods (if included in the scope of supply), at consignee location. OEM Warranty certificates must be submitted by Successful Bidder at the time of delivery of Goods. The seller should guarantee the rectification of goods in case of any break down during the guarantee period. Seller should have well established Installation, Commissioning, Training, Troubleshooting and Maintenance Service group in INDIA for attending the after sales service. Details of Service Centres near consignee destinations are to be uploaded along with the bid.

7. Generic

OPTION CLAUSE: The Purchaser reserves the right to increase or decrease the quantity to be ordered up to 25 percent of bid quantity at the time of placement of contract. The purchaser also reserves the right to increase the ordered quantity by up to 25% of the contracted quantity during the currency of the contract at the contracted rates. Bidders are bound to accept the orders accordingly.

8. Buyer Added Bid Specific ATC

Buyer uploaded ATC document [Click here to view the file.](#)

9. **Generic**

Upload Manufacturer authorization: Wherever Authorised Distributors are submitting the bid, Manufacturers Authorisation Form (MAF)/Certificate with OEM details such as name, designation, address, e-mail Id and Phone No. required to be furnished along with the bid.

Disclaimer

The additional terms and conditions have been incorporated by the Buyer after approval of the Competent Authority in Buyer Organization. Buyer organization is solely responsible for the impact of these clauses on the bidding process, its outcome and consequences thereof including any eccentricity / restriction arising in the bidding process due to these ATCs and due to modification of technical specification and / or terms and conditions governing the bid. Any clause incorporated by the Buyer such as demanding Tender Sample, incorporating any clause against the MSME policy and Preference to make in India Policy, mandating any Brand names or Foreign Certification, changing the default time period for Acceptance of material or payment timeline governed by OM of Department of Expenditure shall be null and void and would not be considered part of bid. Further any reference of conditions published on any external site or reference to external documents / clauses shall also be null and void. If any seller has any objection / grievance against these additional clauses or otherwise on any aspect of this bid, they can raise their representation against the same by using the Representation window provided in the bid details field in Seller dashboard after logging in as a seller within 4 days of bid publication on GeM. Buyer is duty bound to reply to all such representations and would not be allowed to open bids if he fails to reply to such representations.

[This Bid is also governed by the General Terms and Conditions](#)

In terms of GeM GTC clause 26 regarding Restrictions on procurement from a bidder of a country which shares a land border with India, any bidder from a country which shares a land border with India will be eligible to bid in this tender only if the bidder is registered with the Competent Authority. While participating in bid, Bidder has to undertake compliance of this and any false declaration and non-compliance of this would be a ground for immediate termination of the contract and further legal action in accordance with the laws.

---Thank You---

Pneumatic operated Knife Gate valve DN 100:

Specification :

Size- DN 100

Application Medium:Pulp

ACTUATOR-Pneumatic double acting

Body: CF8M

Gate: AISI 316 HARDCHROME PLATED

Seat: METAL

Packing: ST PTFE IMPREGNATED SYNTHETIC FIBRE WITH EPDM - O RING

Flange: ANSI 150

GLAND FOLLOWER: CF8M

PISTON ROD:SS304

YOKE- MS POWDER COATED

VALVE FASTENERS: SS304

WORKING PRESSURE - 10 BAR

Permissible operation temperature: 120°C

Dimension of Valve and flange should be as per attached

Pneumatic operated Knife Gate valve DN 200:

Specification :

Size- DN 200

Application Medium:Pulp

ACTUATOR-Pneumatic double acting

Body: CF8M

Gate: AISI 316 HARDCHROME PLATED

Seat: METAL

Packing: ST PTFE IMPREGNATED SYNTHETIC FIBRE WITH EPDM - O RING

Flange: ANSI 150

GLAND FOLLOWER: CF8M

PISTON ROD:SS304

YOKE- MS POWDER COATED

VALVE FASTENERS: SS304

WORKING PRESSURE - 10 BAR

Permissible operation temperature: 120°C

Dimension of Valve and flange should be as per attached

Pneumatic operated Knife Gate valve DN 250:

Specification :

Size- DN 250

Application Medium:Pulp

ACTUATOR-Pneumatic double acting

Body: CF8M

Gate: AISI 316 HARDCHROME PLATED

Seat: METAL

Packing: ST PTFE IMPREGNATED SYNTHETIC FIBRE WITH EPDM - O RING

Flange: ANSI 150

GLAND FOLLOWER: CF8M

PISTON ROD:SS304

YOKE- MS POWDER COATED

VALVE FASTENERS: SS304

WORKING PRESSURE - 10 BAR

Permissible operation temperature: 120°C

Dimension of Valve and flange should be as per attached

Pneumatic operated Knife Gate valve DN 300:

Specification :

Size- DN 300

Application Medium:Pulp

ACTUATOR-Pneumatic double acting

Body: CF8M

Gate: AISI 316 HARDCHROME PLATED

Seat: METAL

Packing: ST PTFE IMPREGNATED SYNTHETIC FIBRE WITH EPDM - O RING

Flange: ANSI 150

GLAND FOLLOWER: CF8M

PISTON ROD:SS304

YOKE- MS POWDER COATED

VALVE FASTENERS: SS304

WORKING PRESSURE - 10 BAR

Permissible operation temperature: 120°C

Dimension of Valve and flange should be as per attached

Pneumatic operated Knife Gate valve DN 350:

Specification :

Size- DN 350

Application Medium:Pulp

ACTUATOR-Pneumatic double acting

Body: CF8M

Gate: AISI 316 HARDCHROME PLATED

Seat: METAL

Packing: ST PTFE IMPREGNATED SYNTHETIC FIBRE WITH EPDM - O RING

Flange: ANSI 150

GLAND FOLLOWER: CF8M

PISTON ROD:SS304

YOKE- MS POWDER COATED

VALVE FASTENERS: SS304

WORKING PRESSURE - 10 BAR

Permissible operation temperature: 120°C

Dimension of Valve and flange should be as per attached

Pneumatic operated Knife Gate valve through Conduit DN 150:

Specification :

Size- DN 150

Application Medium: Pulp

ACTUATOR- Pneumatic double acting

Body: CF8M

Gate: AISI 316 HARDCHROME PLATED

Seat: METAL

Packing: ST PTFE IMPREGNATED SYNTHETIC FIBRE WITH EPDM - O RING

Flange: ANSI 15

GLAND FOLLOWER: CF8M

PISTON ROD: SS304

MS POWDER COATED

VALVE FASTENERS: SS304

WORKING PRESSURE - 10 BAR

permissible operation temperature: 120°C

With feed back sensor/limit switch

Dimension of Valve and flange should be as per attached drawing.

Pneumatic operated Knife Gate valve DN 125:

Specification :

Size- DN 125

Application Medium:Pulp

ACTUATOR-Pneumatic double acting

Body: CF8M

Gate: AISI 316 HARDCHROME PLATED

Seat: METAL

Packing: ST PTFE IMPREGNATED SYNTHETIC FIBRE WITH EPDM - O RING

Flange: ANSI 150

GLAND FOLLOWER: CF8M

PISTON ROD:SS304

YOKE- MS POWDER COATED

VALVE FASTENERS: SS304

WORKING PRESSURE - 10 BAR

Permissible operation temperature: 120°C

Dimension of Valve and flange should be as per attached

Pneumatic operated Knife Gate valve DN 100:

Drawing and Dimensions (mm):

DN	A	H	G	K	n
100	50	525-575	>105	180	8

Flange

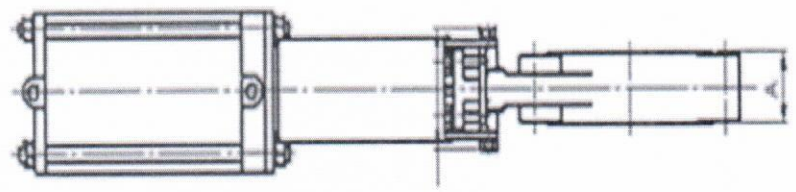
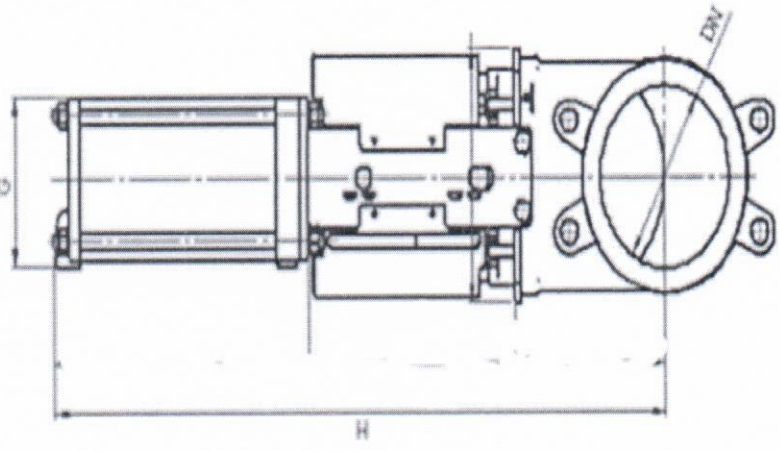
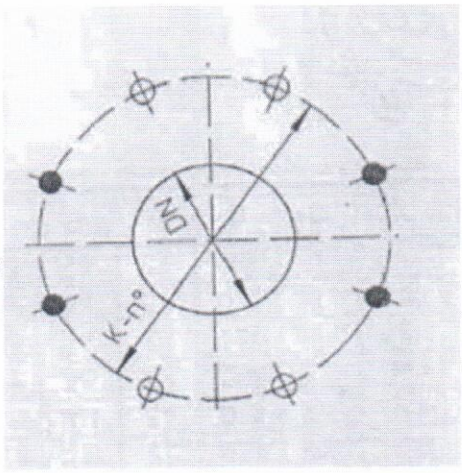

Pneumatic operated Knife Gate valve DN 200:

Drawing and Dimensions (mm):

DN	A	H	G	K	n
200	60	855-895	>165	295	8

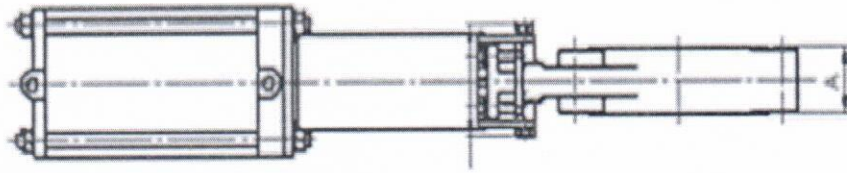
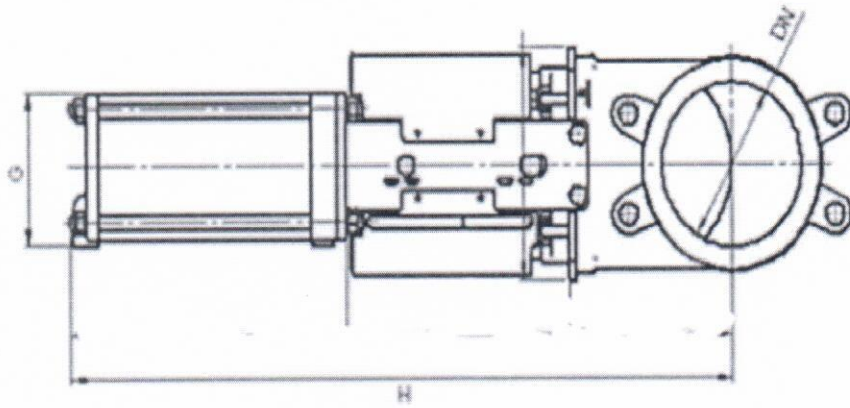
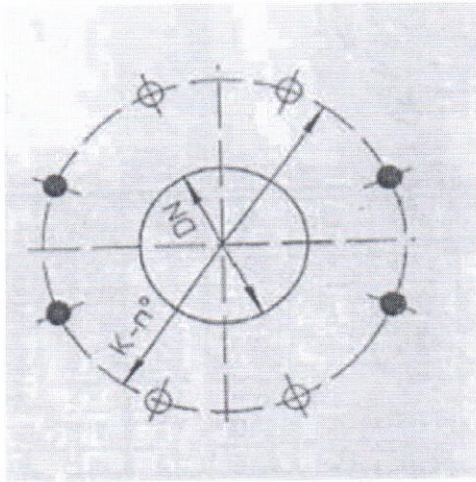

Valve Drawing

Pneumatic operated Knife Gate valve DN 250:

Drawing and Dimensions (mm):

DN	A	H	G	K	n
250	60-70	1030-1055	>210	350	12

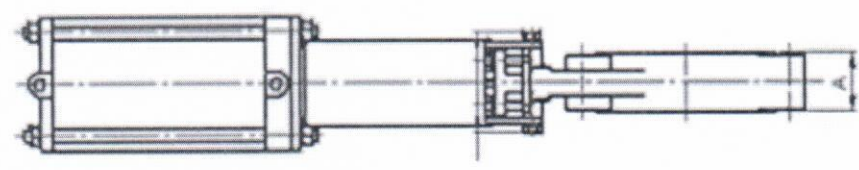
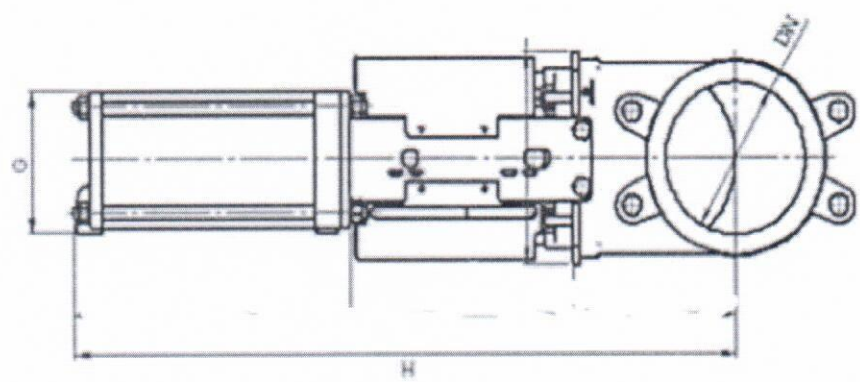
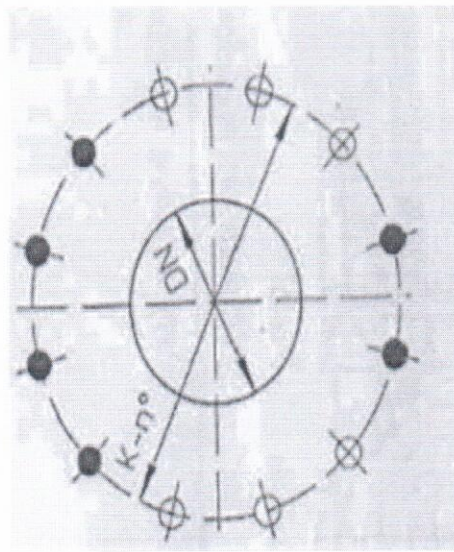

Valve Drawing

Pneumatic operated Knife Gate valve DN 300:

Drawing and Dimensions (mm):

DN	A	H	G	K	n
300	70	1192	>210	400	12

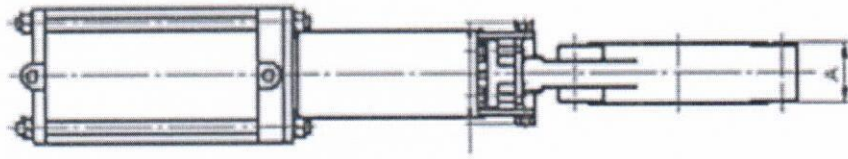
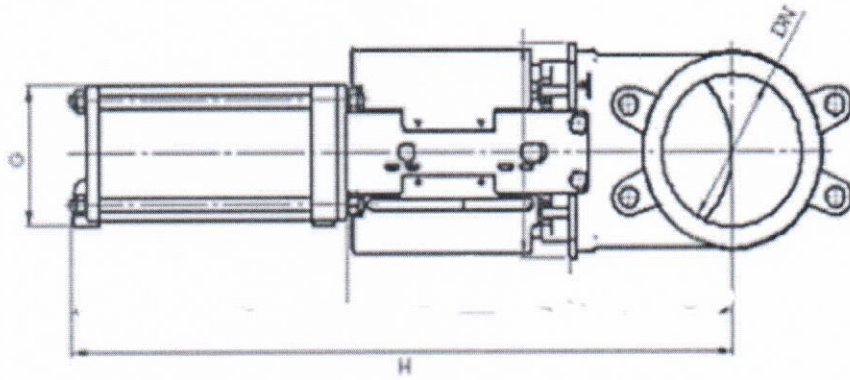
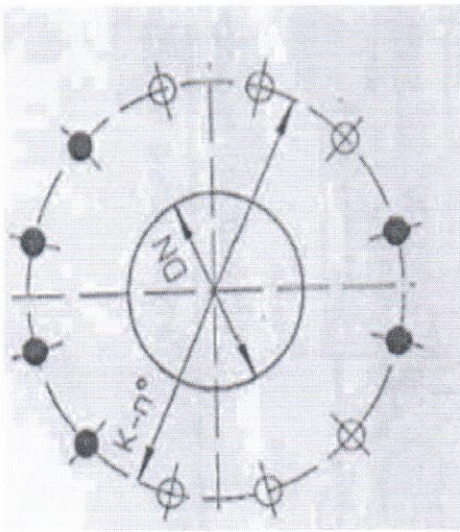

Pneumatic operated Knife Gate valve DN 350:

Drawing and Dimensions (mm):

DN	A	H	G	K	n
350	70-72	1370-1400	>265	460	16

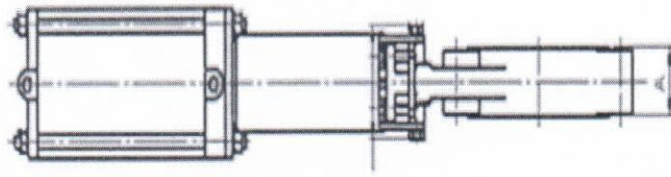
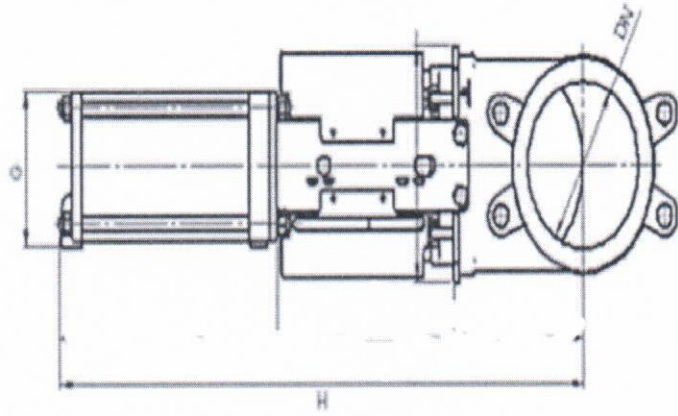
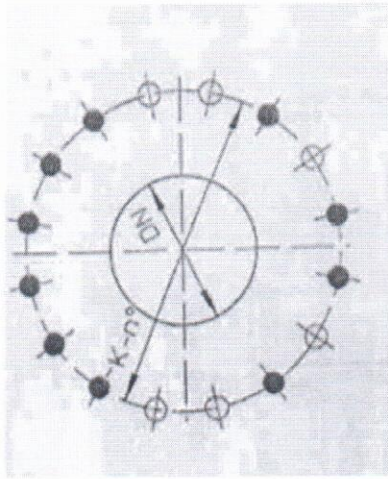

Valve Drawing

Pneumatic operated Knife Gate valve DN 350:

Drawing and Dimensions (mm):

DN	A	H	G	K	n
350	70-72	1370-1400	>265	460	16

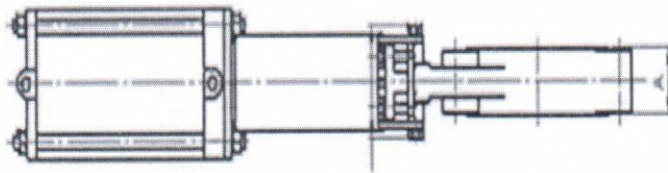
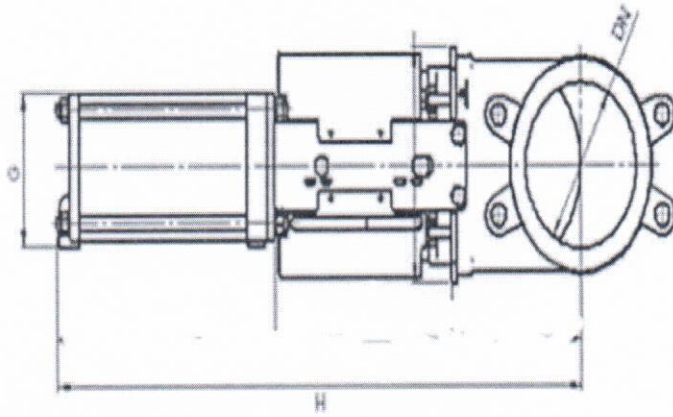
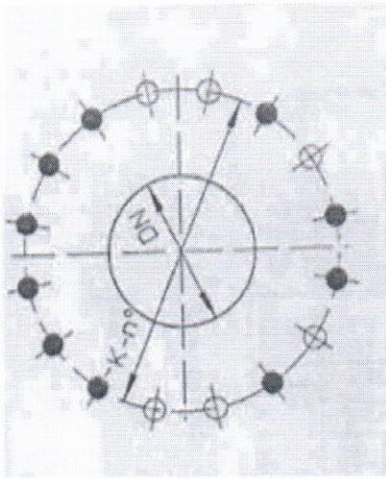

Valve Drawing

Item no. 70

Pneumatic operated Knife Gate valve through Conduit DN 150:

Drawing and Dimensions (mm):

DN	A	B	H	k	D	W	J
150	251 - 255	60	483- 497	240	175 -185	170-190	1200-1243

flange connection

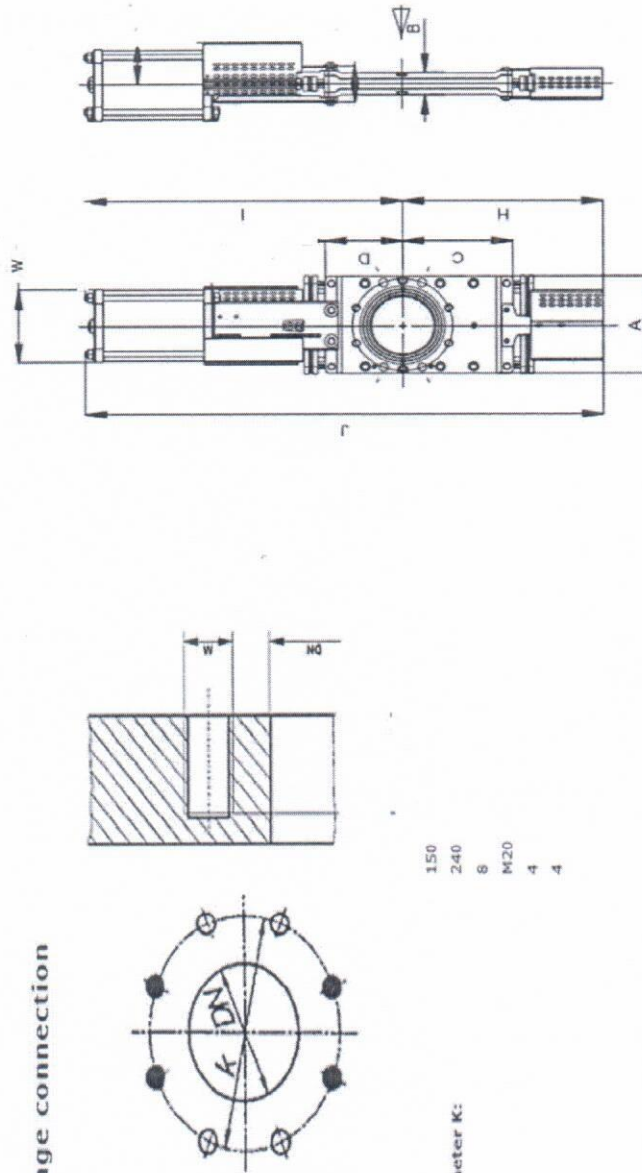

- DN: 150
- diameter K: 240
- Z: 8
- M: M20
- Z1: 4
- Z2: 4

● Z1 = number of tapped holes
 ○ Z2 = number of through-holes

Pneumatic operated Knife Gate valve DN 125:

Drawing and Dimensions (mm):

DN	A	H	G	K	n
125	50-55	615-650	>130	210	8

Flange

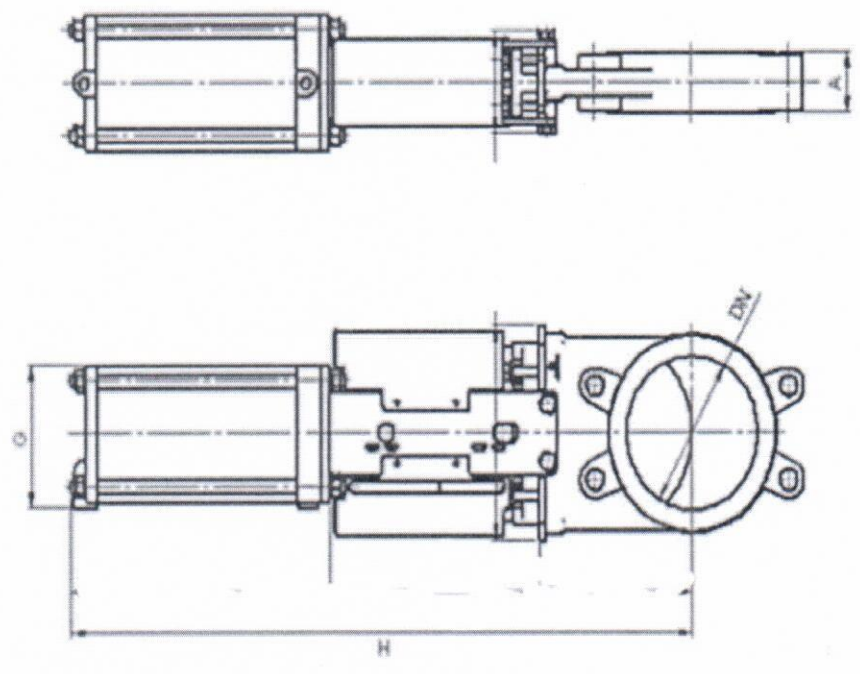
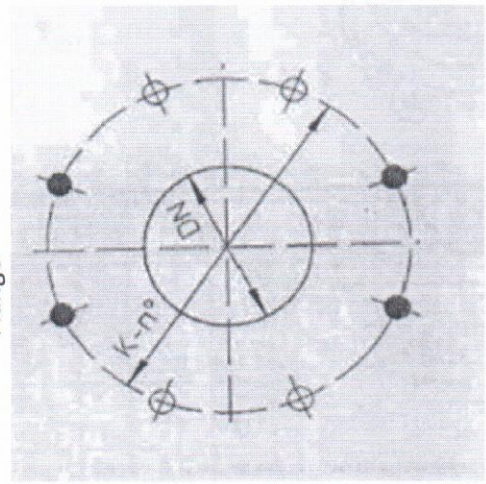

Valve Drawing